

SPRAY KING®

WATER TANKS

TANKS FOR RIGID FRAME TRUCKS

SK15RF • SK20RF

DESIGNED TO BE SAFE & EASY TO MAINTAIN

Tanks available in 15k and 20k gallon capacities

WHAT SETS IT APART

- **Patent-pending Tortuga-shaped tank** provides lower center of gravity and a more stable driving experience
- **Tank interior coated with acrylic DTM** (direct to metal) material for superior corrosion resistance
- **An internal corrugated baffle system** reduces surge effect – increasing stability and tank structural integrity
- **Subharmonic stress reduction**, a vibration stress relief process, is applied to all tanks to help reduce stress and premature metal distortion

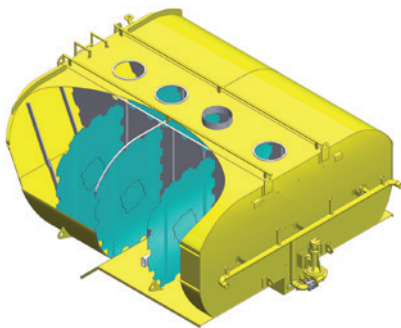
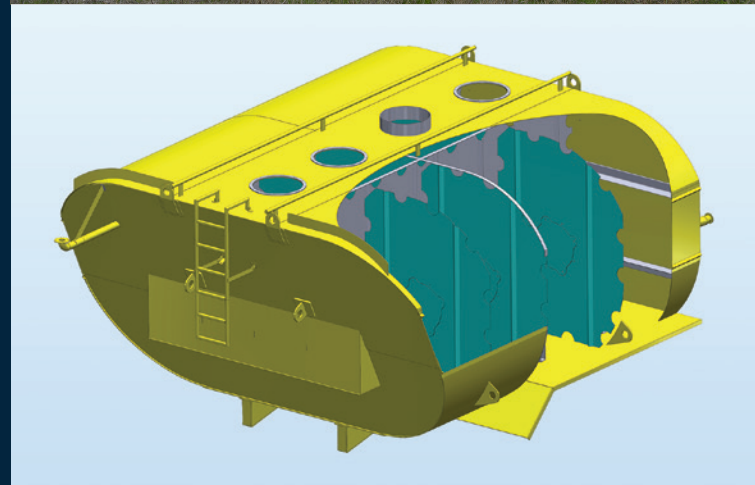

PRECISE TAILORING & RIGOROUS STANDARDS

- Touchscreen system controls spray head operation, provides visibility to tank water level, and is programmed to safely shut down pump system when water level is low
- Adjustable spray heads provide complete coverage in a variety of applications and environments
- Close-to-ground spray head system to allow quicker coverage and less atomization
- Large, screened intake cage to prevent blockage and allow longer run time between scheduled maintenance intervals
- Optional vinyl branding allows you to promote your company



HOW REPUTATIONS ARE FORGED

Ever since Benjamin Holt produced his first horse-drawn harvester in the late 1800's, HOLT Manufacturing has been building the products that move industries, and you, forward.