



User Guide

For Spray King®

Water Tank

for

Cat® 725/730/740/745

Off-Highway Truck

Tank Models

SK5AT

SK6AT

SK8AT

SK9AT

HOLT Manufacturing

2000 Texas Central Parkway

Building 100

Waco, TX 76712

844.465.8634

Email: SprayKing@holtmfg.com

©Copyright 2026 Holt Texas, Ltd. d/b/a HOLT Manufacturing. All rights reserved. HOLT, Spray King, HOLT CAT, as well as corporate and product identity used herein are registered trademarks of Holt Texas, Ltd., 5665 SE Loop 410, San Antonio, TX 78222, and may not be used without permission.

TABLE OF CONTENTS

| | |
|---|-----------|
| SAFETY FIRST: BEFORE STARTING | 4 |
| DEFINITIONS | 5 |
| STANDARD FEATURES & CAPABILITIES | 7 |
| SPECIFICATIONS | 10 |
| SK5AT – 5,000 GALLON TANK FOR CAT 725..... | 10 |
| SK6AT – 6,000 GALLON TANK FOR CAT 730..... | 11 |
| SK8AT – 8,000 GALLON TANK FOR CAT 740..... | 12 |
| SK9AT – 9,000 GALLON TANK FOR CAT 745..... | 13 |
| WARRANTY..... | 14 |
| PRE-OPERATION INSPECTION..... | 16 |
| WALK AROUND INSPECTION..... | 16 |
| OPERATING THE TANK..... | 17 |
| FILLING THE TANK | 17 |
| SPRAY HEADS..... | 18 |
| SPRAY PERFORMANCE DATA | 19 |
| <i>Adjusting Spray Heads</i> | 20 |
| SPRAY OPERATIONS..... | 21 |
| IN-CAB TOUCH SCREEN CROSSFIRE SYSTEM | 21 |
| <i>In-Cab Touch Screen Bosch System</i> | 23 |
| <i>In-Cab Push Button Control System</i> | 25 |
| <i>Disengaging Spray Heads</i> | 25 |
| <i>Driving While Spraying</i> | 25 |
| HOSE REEL..... | 26 |
| <i>Using the Hose Reel</i> | 26 |
| <i>Stowing Hose</i> | 26 |
| USING THE GRAVITY BAR..... | 27 |
| MONITOR OPERATION | 28 |
| <i>Rotation Limits</i> | 28 |
| ENGAGING THE WATER MONITOR..... | 29 |
| OPERATING THE ROJO SPRAYERS (OPTIONAL) | 30 |
| OTHER PARTS: PUMP..... | 31 |
| <i>Draining the Pump</i> | 32 |
| IFM HYDRAULIC CONTROLLER (INSTALLED 2022 -)..... | 34 |
| CROSSFIRE HYDRAULIC CONTROLLER (INSTALLED PRE-2022) | 35 |
| BUTTERFLY VALVE | 36 |
| MAINTENANCE..... | 37 |
| PUMP MAINTENANCE, START UP AND WINTERIZATION | 37 |
| MAINTENANCE: WATER MONITOR..... | 36 |
| ABOUT HOLT MANUFACTURING | 37 |

SAFETY FIRST: BEFORE STARTING

Read and become familiar with the basic safety and operations manual for your Cat® truck as well as with the information in this guide for operation of the water tank. Your safety, your coworkers' safety, and the quality of the productivity of the equipment you're operating depend on a thorough walkaround inspection before operations begin to ensure your machine is in safe working order. Make sure you are trained in the safe operation of your Cat machine and the Spray King water tank before starting.

This manual contains information necessary to safely operate the HOLT Spray King® water truck, including basic maintenance procedures. For any questions, please call HOLT Manufacturing, 844.465.8634.

Follow HOLT Manufacturing instructions to operate and maintain your Spray King® water tank. Unless otherwise instructed by this guide or by HOLT or your Cat dealer, use only HOLT supplied parts during installation for your safety and to maintain your warranty. Use appropriate personal protective equipment and clothing, safety helmets, safety harnesses, and procedures.

Before performing any work, proper machine power lockout procedures should be followed, and wheels should be chocked.

NO pipe, tubing, or conduit on top of the tank should be used to tie off or used as anchor points or tie off points as part of a fall arrest system.

Contact Us

For questions regarding your tank operation, troubleshooting, or maintenance, please contact HOLT Manufacturing, at 844.465.8634.

For parts, call 844.465.8634 or email SprayKing@holtmfg.com.

DEFINITIONS

Definitions of symbols and words used in this manual and in the operation of the HOLT Spray King water truck. Follow safety precautions before proceeding.



WARNING: Follow safety precautions before proceeding.



WARNING: Non-potable. Water held within tank is non-potable. Do not use tank for transport of water intended for human or animal consumption or serious injury or death may result.



WARNING: Rotating Shaft. Do not place your hand or tools within pump bell while pump is rotating and/or pressure held within the motor supply hose.



WARNING: Slip and Fall Hazard. Don't walk on the top of tank without fall arrest PPE. Serious injury or death could result from a fall.



WARNING: Trip Hazard. Take care using steps and walking on top of tank.



WARNING: Confined Space. Permit-required confined spaces contain hazards that could cause death or serious injury to workers.



WARNING: Freeze Hazard. Drain tank, fill pipe, pump, monitor, and valves in freezing weather.



WARNING: Crush/Pinch Risk. Do not place your hand or tools near the butterfly valve (if equipped) when the truck is in operation.



WARNING: Low Clearance/Risk of Injury. Use caution when walking around the back of the truck and tank.



WARNING: Check for pedestrians before spraying. Before engaging spray heads or monitor, make sure there are no pedestrians present.



WARNING: Tank must be dry/empty before lifting; use lift points.



WARNING: Make sure tank is secured using tie down points before transporting.



WARNING: NO pipe, tubing, or conduit on top of the tank should be used to tie off or used as anchor points or tie off points as part of a fall arrest system.

STANDARD FEATURES & CAPABILITIES

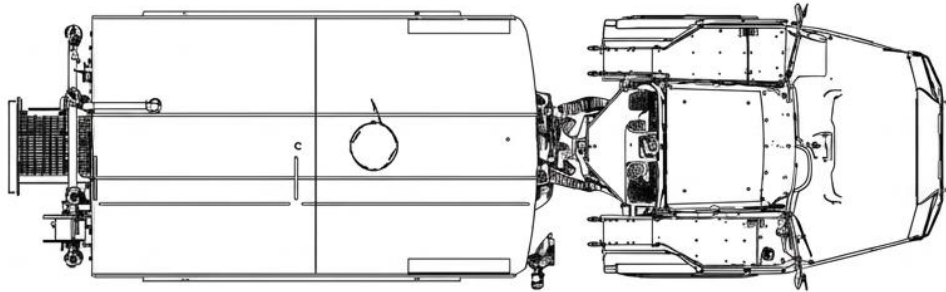

STANDARD FEATURES:

- WATER MONITOR
- FOUR REAR SPRAYHEADS
- HOSE REEL WITH NOZZLE
- TOUCHSCREEN CONTROLS
- BACKUP CAMERA

OPTIONAL FEATURES:

- PUSH-BUTTON CONTROLS
- SIDE SPRAYERS
- 340° CAMERA VISION SYSTEM
- GRAVITY BAR

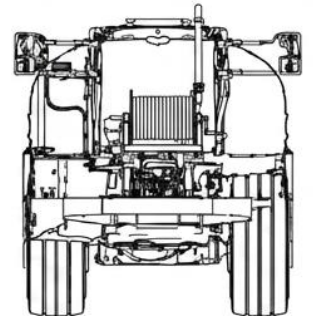
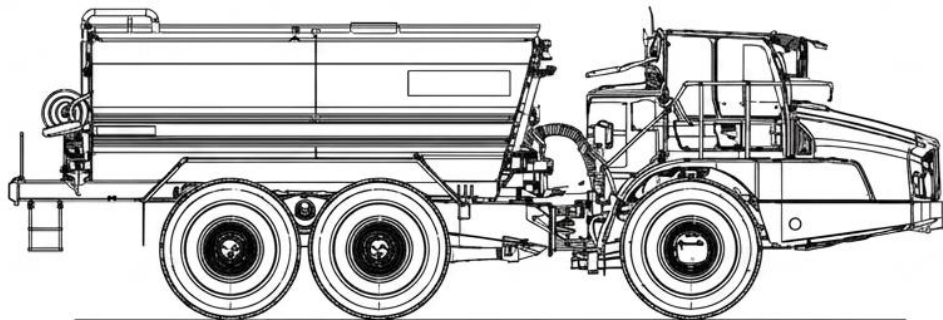

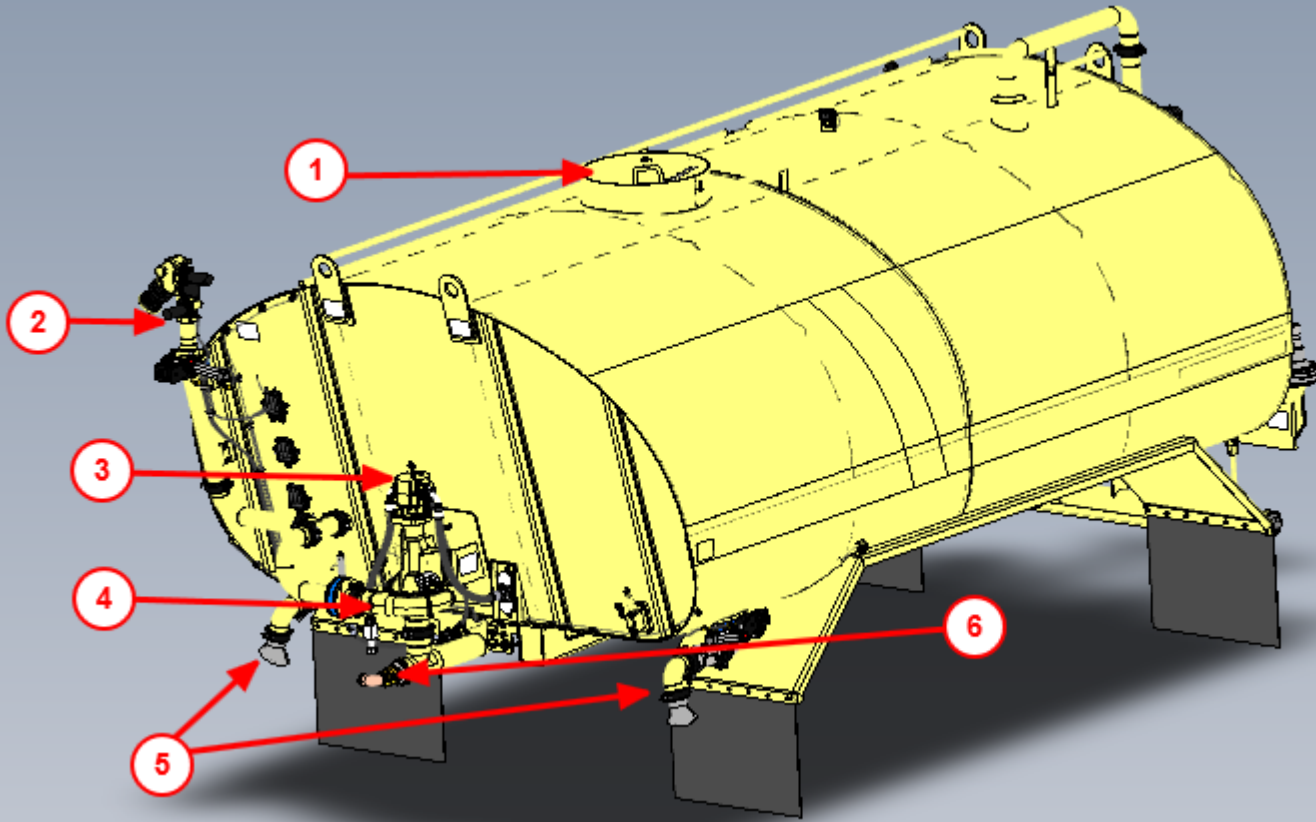

1. Sock fill port
2. Water monitor
3. Hydraulic motor
4. Water pump
5. Side slop spray heads
6. 2" tank drain valve

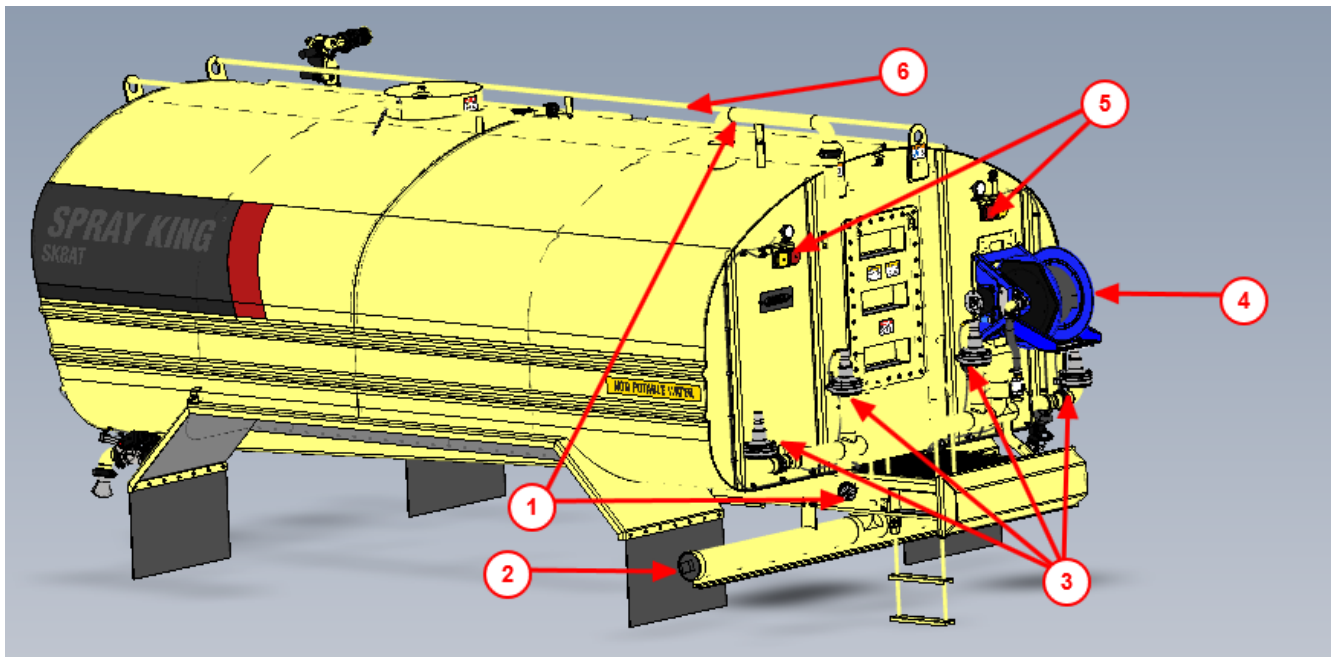

1. 3" cam lock hydrant fill port
2. Gravity bar
3. Up to 4 spray heads
4. Hose reel with 50 ft hose
5. CAT tail lamp assemblies
6. Grab handles (Not designed as a tie off)

SPECIFICATIONS

SK5AT – 5,000 gallon tank for Cat 725

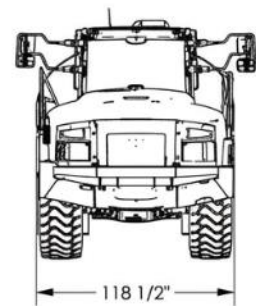
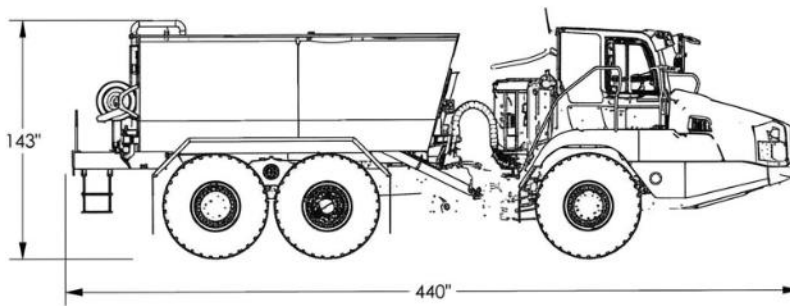
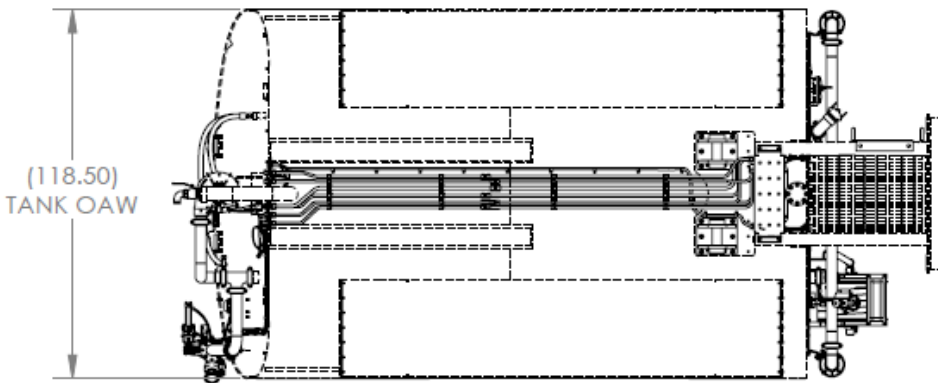
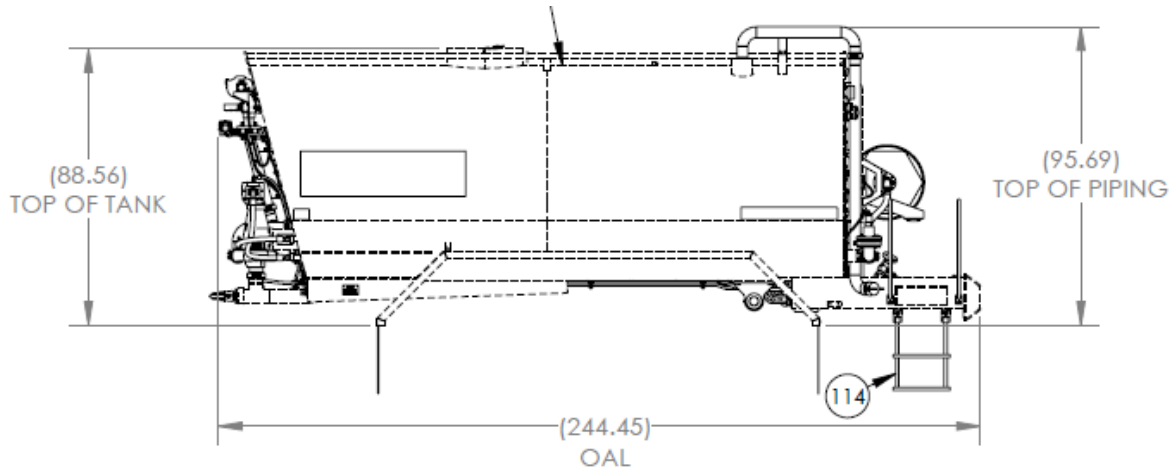

725 WATER TRUCK - SK5AT

TANK WEIGHT: 12,487 lbs

TRUCK WEIGHT: 43,654 lbs

TOTAL WEIGHT: 56,141 lbs

SK6AT – 6,000 gallon tank for Cat 730

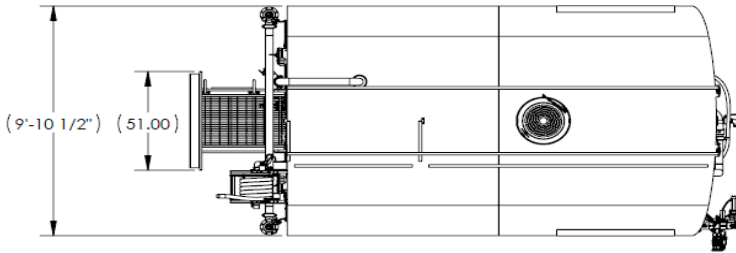

TANK WEIGHT (NO FLUIDS): 13,450 LBS. (EST.)

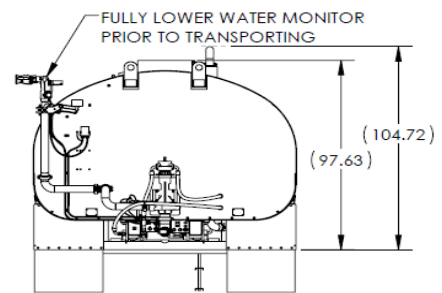
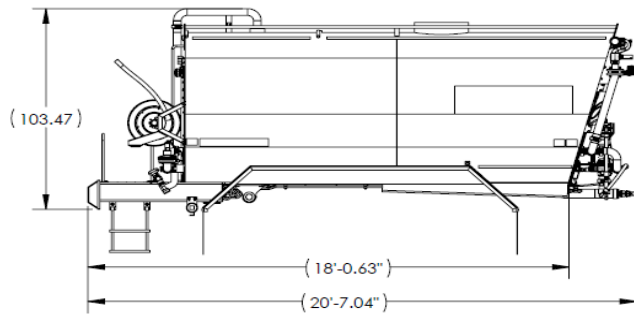

TECHNICAL INFORMATION:

OPERATIONAL WEIGHT (NO WATER): 56,500 LBS. (EST.)
 OPERATIONAL WEIGHT (FULL TANK): 105,500 LBS. (EST.)
 WATER TANK CAPACITY (APPROX.): 6000 GALLONS (US)
 MAX. WATER PUMP GPM (APPROX.): 600

STANDARD FEATURES:

- TOUCHSCREEN CONTROLS
- REAR SPRAYBAR
- WATER MONITOR
- HOSE REEL WITH NOZZLE

OPTIONAL FEATURES:

- PUSH BUTTON CONTROLS
- REAR GRAVITY BAR
- SIDE SPRAYERS

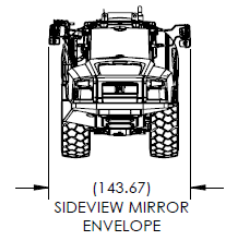
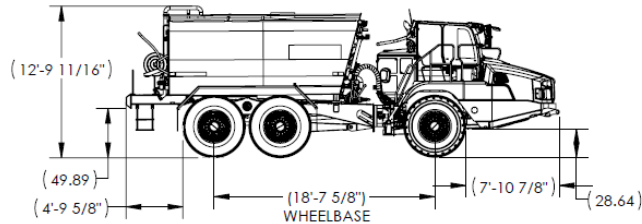
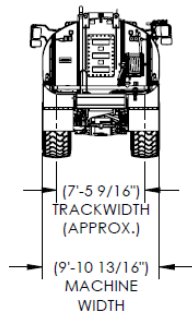
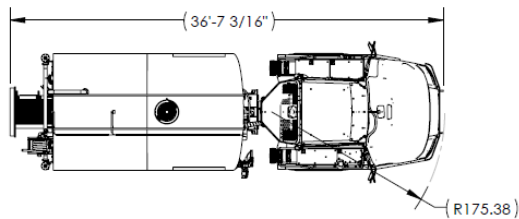

SK8AT – 8,000 gallon tank for Cat 740

Tank Weight: 17,500 lbs.

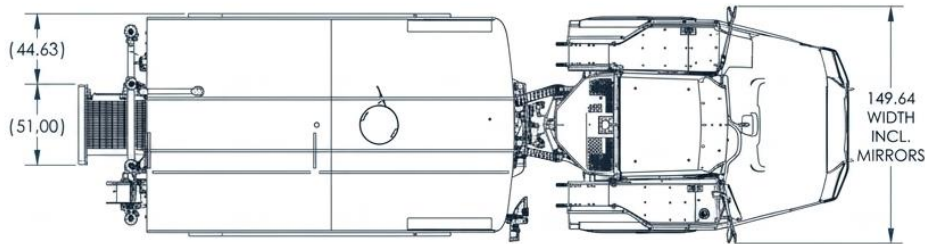
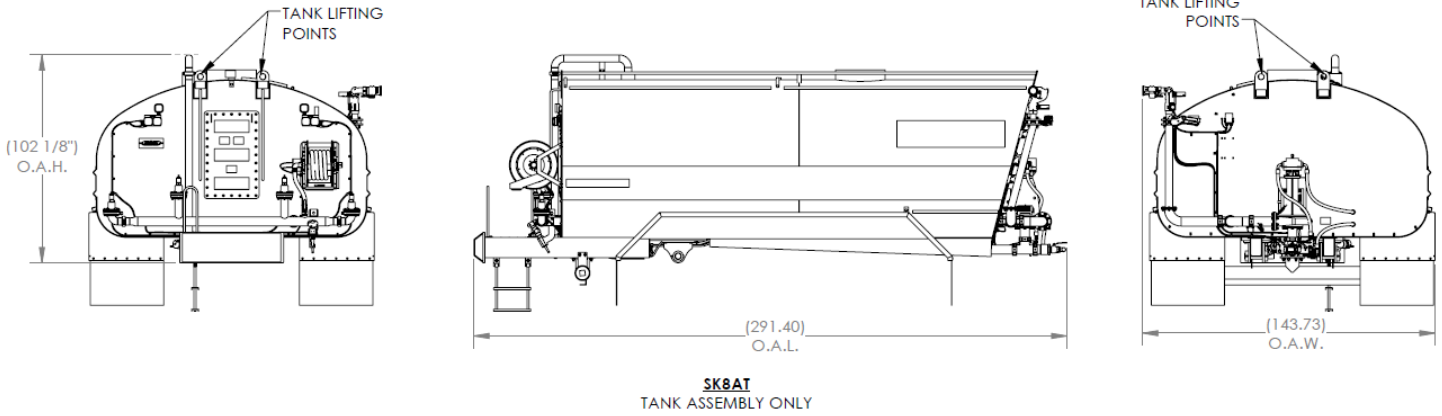

STANDARD FEATURES:

- WATER MONITOR
- FOUR REAR SPRAYHEADS
- HOSE REEL WITH NOZZLE
- TOUCHSCREEN CONTROLS
- BACKUP CAMERA

OPTIONAL FEATURES:

- PUSH-BUTTON CONTROLS
- SIDE SPRAYERS
- 360° CAMERA VISION SYSTEM
- GRAVITY BAR

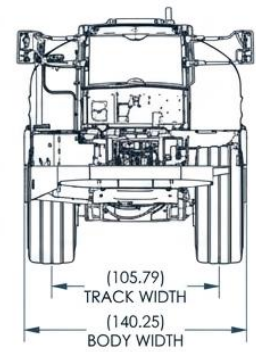
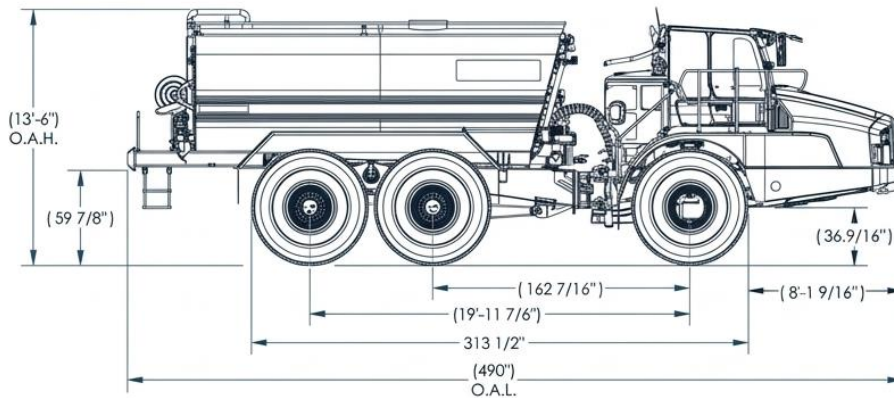

NOTES:

- SKBAT CURB WEIGHT: 78,000 LBS. (APPROX.)
- OPERATIONAL WEIGHT (FULL TANK): 145,000 LBS. (EST.)
- WATER TANK CAPACITY: 8,000 GALLONS (ADDS 66,720 LBS.)
- GROUND PRESSURE PER TIRE (FULLY LADEN): 50 PSI. (FRONT) 62PSI (REAR)

* ALL DATA GENERATED USING DENSITY OF CLEAN NON-POTABLE WATER

SK9AT – 9,000 gallon tank for Cat 745

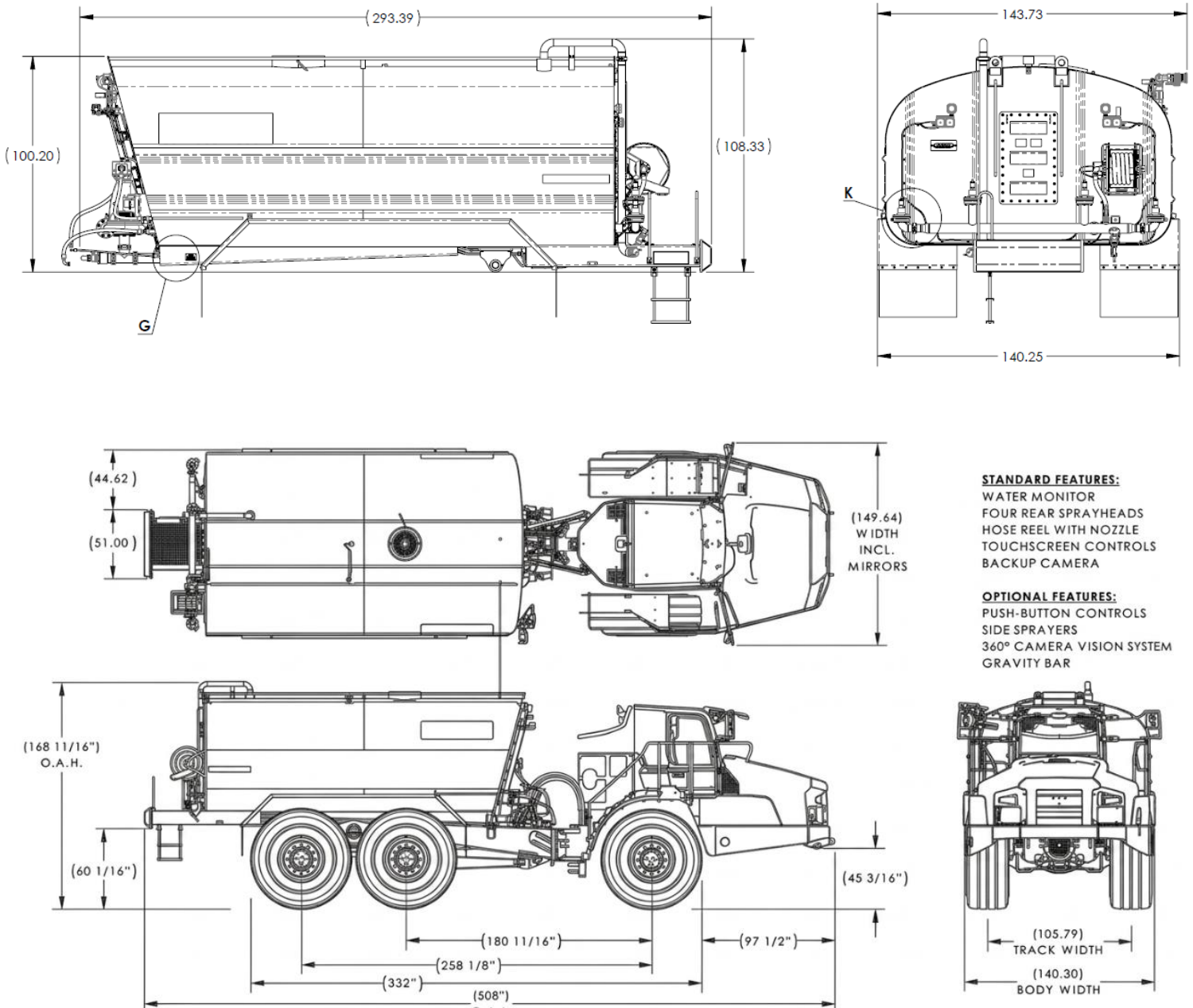

Notes:

1. SK Curb Weight: approximately 80,100 lbs.
2. SK Tank Assembly only: approximately 18,100 lbs.
3. Water capacity: 9,000 gallons (approximately 75,100 lbs.)

WARRANTY

HOLT MANUFACTURING® LIMITED WARRANTY

The Manufacturer warrants that products produced shall be free from defects in material and workmanship that develop under normal use for a period of one year from the date of delivery to buyer on all products. The preceding shall be the exclusive remedy of the buyer and the exclusive liability of the Manufacturer. Our warranty excludes normal replaceable wear items (e.g. gaskets, wear parts, seals, O-rings, belts, drive chains, clutches, batteries, tires, etc.). Any equipment, part or product which is furnished by the Manufacturer but manufactured by another, bears only the warranty given by such other manufacturer. This Limited Warranty is non-transferable.

Warranty is voided by product abuse, alterations, use of equipment in applications for which it was not intended, use of non-manufacturer parts or failure to follow documented service instructions. Equipment which is substantially damaged by collision, accident, flood, fire, vandalism or other similar occurrences are not covered by this Limited Warranty. Any delays in Manufacturer's performance under the Warranty resulting from strikes, acts of God, or other occurrences beyond the reasonable control of Manufacturer that cause any type of loss to buyer are not covered and will not result in any additional compensation to buyer. Buyer will pay Manufacturer its cost to diagnose and investigate claims unless the repairs are covered under this Limited Warranty. **The foregoing warranty is exclusive of all other warranties whether written or oral, expressed or implied. No warranty of merchantability or fitness for a particular purpose shall apply.** The agents, dealers and employees of Manufacturer are not authorized to make modifications to this warranty, or additional warranties binding on the Manufacturer. Therefore, additional statements, whether oral or written, do not constitute warranty and should not be relied upon.

The Manufacturer's sole responsibility for any breach of the foregoing warranty provisions, with respect to any product or part not conforming to the Warranty or the description herein contained, is at the Manufacturer's option: (a) to repair, replace, or refund such product or parts upon the prepaid return thereof to location designated specifically by the Manufacturer (product returns not shipped prepaid will be refused); in the event buyer requests an expedited repair charges may include overtime if applicable, (b) as an alternative to the foregoing modes of settlement the Manufacturer's dealer may repair defective units with reimbursement for expenses if expressly allowed for in writing by Manufacturer. A written description of problem or cause must accompany all warranty claims. All repairs must be performed by Manufacturer and at a location designated by Manufacturer. Manufacturer shall pay usual and customary ground shipping charges for parts needed for warrantable repairs made at a Manufacturer's location. This Warranty does not apply to routine maintenance.

Except as set forth here in above and without limitation of the above, there are no warranties or other affirmation which extend beyond the description of the products on the fact here of, or as to operational efficiency, product reliability, or maintainability or compatibility with products furnished by others. **In no event, whether as a result of breach of contract or warranty or alleged negligence, shall the Manufacturer, be liable for special, indirect, incidental, punitive or consequential damages including but not limited to: loss of profits or revenue, personal injury, property damage, strict liability, loss of use of the product or any associated product, cost of capital, cost of substitute products, facilities or services or claims of customers.** The Manufacturer does not assume responsibility for any accident due to equipment modification, unless approved prior in writing by a Holt Manufacturing engineer.

No claim will be allowed for products lost or damaged in transit. Such claims should be filed with the carrier within fifteen days.

THE PARTIES HERETO SHALL SUBMIT TO BINDING ARBITRATION ANY DISPUTED QUESTIONS OR CONTROVERSY ARISING FROM OR RELATED TO THIS LIMITED WARRANTY, OR RELATED TO THE TRANSACTION CONTEMPLATED BY THIS LIMITED WARRANTY. ANY SUCH ARBITRATION SHALL BE CONDUCTED IN BEXAR COUNTY, TEXAS UNDER THE COMMERCIAL ARBITRATION RULES OF THE AMERICAN ARBITRATION ASSOCIATION. THE ISSUE OF WAIVER PURSUANT TO THIS PARAGRAPH IS AN ARBITRABLE ISSUE. THE AWARD OF THE ARBITRATORS SHALL BE FINAL AND NON-APPEALABLE.

THE PROVISIONS OF THIS LIMITED WARRANTY SHALL BE INTERPRETED AND GOVERNED IN ACCORDANCE WITH THE LAWS OF THE STATE OF TEXAS.

PRE-OPERATION INSPECTION

Walk Around Inspection

Make a detailed walk around inspection the start to every workday.

At ground level, look for:

- Damage
- Excessive wear
- Loose or missing bolts
- Debris or trash buildup
- Damaged or missing safety signs

On a second trip around, additionally:

- Examine all tank mounts for tightness
- Examine all seals, covers and hoses for leaks
- Check fluid levels
- Check tires and tire inflation
- Check that windows are clear and that all steps and handrails are clean and clear
- Store and secure all loose tools and objects in the cab



OPERATING THE TANK

Filling the Tank

To fill with a hose from an existing water source or hydrant, fill the tank through 3" camlock fill port at the left rear corner.

The tank may also be filled through the manhole port on the top of the tank.

On older machines the manhole cover has holes in it, but it is recommended to remove the cover when using a waterfall sock fill. Stow the cover for future use.

On current production tanks there is a basket style insert that does not need to be removed. It allows the waterfall sock to drop inside the tank reducing splash back.

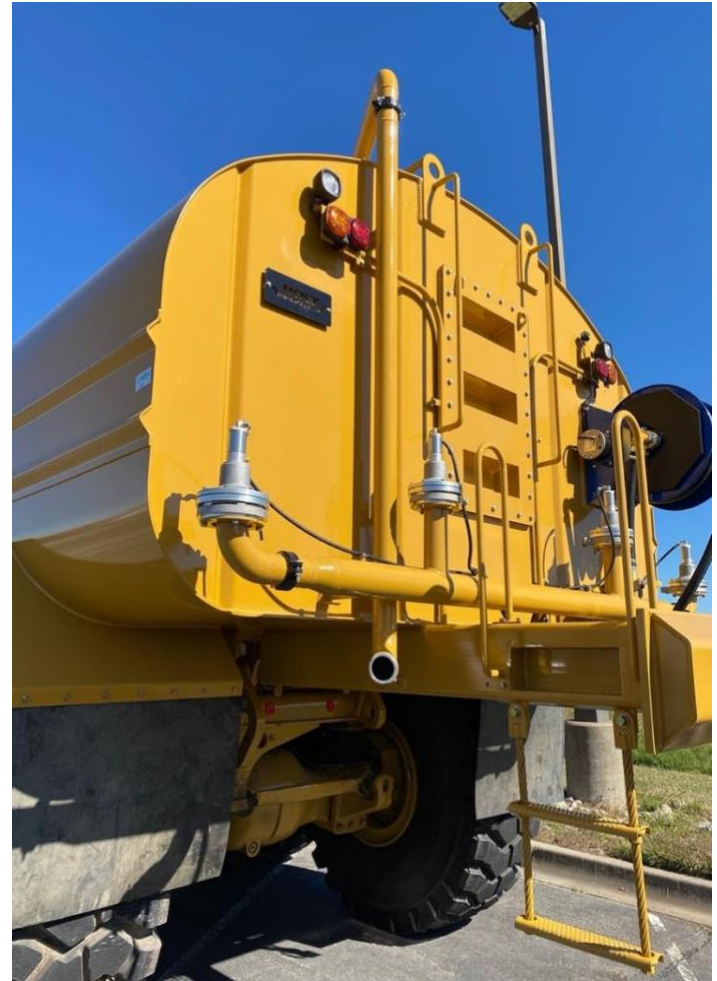

Important Note: During water fill, the HMI screen for (CROSSFIRE AND IFM SYSTEMS) in the cab will indicate the water level in the tank. When the level gets to about 90%, the tank is close to full. If water reaches the sensor in the roof of the tank and goes over the top of the sensor, the fill level indicator will drop to about 70% temporarily but will return to full when the water level drops again.



WARNING: NO pipe, tubing, or conduit on top of the tank should be used to tie off or used as anchor points or tie off points as part of a fall arrest system.



WARNING: Low clearance around the rear of the tank. Take precautions to avoid injury.

Spray Heads

Note: Cat 725/730 models have 2 sprayers; Cat 740-745 models have 4 sprayers.

Examine all sprays heads for excessive wear, dirt, and debris. Make sure that the exhausts filter (brass fitting) is clean and clear.

Spray heads, two or four, depending on your model, are mounted on the rear of the tank. The heads rotate on the base plate to direct the discharge fan for optimum spray patterns. There is an adjustable ring to control intensity and spray width, as well as a vertical adjustment.



Spray Performance Data

| 5,000 Gallon Tank | Gallons per minute (GPM) | Ground Speed (MPH) | Distance (miles) |
|--|---------------------------------|---------------------------|-------------------------|
| 2 Spray Heads, Fine Spray (1/4 inch slot) | 950 | 10 | 0.88 |
| 2 Spray Heads, Fine Spray (1/4 inch slot) | 950 | 15 | 1.3 |
| 2 Spray Heads, Fine Spray (3/8 inch slot) | 1200 | 10 | 0.67 |
| 2 Spray Heads, Heavy Spray (3/8 inch slot) | 1200 | 15 | 1 |
| 6,000 Gallon Tank | Gallons per minute (GPM) | Ground Speed (MPH) | Distance (miles) |
| 2 Spray Heads, Fine Spray (1/4 inch slot) | 950 | 10 | 1 |
| 2 Spray Heads, Fine Spray (1/4 inch slot) | 950 | 15 | 1.5 |
| 2 Spray Heads, Fine Spray (3/8 inch slot) | 1200 | 10 | 0.8 |
| 2 Spray Heads, Heavy Spray (3/8 inch slot) | 1200 | 15 | 1.2 |
| 8,000 Gallon Tank | Gallons per minute (GPM) | Ground Speed (MPH) | Distance (miles) |
| 4 Spray Heads, Fine Spray (7/4 inch slot) | 1500 | 10 | 0.88 |
| 4 Spray Heads, Fine Spray (7/4 inch slot) | 1500 | 15 | 1.3 |
| 4 Spray Heads, Heavy Spray (3/8 inch slot) | 1575 | 10 | 0.8 |
| 4 Spray Heads, Heavy Spray (3/8 inch slot) | 1575 | 15 | 1.3 |
| 9,000 Gallon Tank | Gallons per minute (GPM) | Ground Speed (MPH) | Distance (miles) |
| 4 Spray Heads, Fine Spray (7/4 inch slot) | 1500 | 10 | 1 |
| 4 Spray Heads, Fine Spray (7/4 inch slot) | 1500 | 15 | 1.5 |
| 4 Spray Heads, Heavy Spray (3/8 inch slot) | 1575 | 10 | 0.9 |
| 4 Spray Heads, Heavy Spray (3/8 inch slot) | 1575 | 15 | 1.4 |

Adjusting Spray Heads

To adjust spray heads, loosen the black adjusting ring knob and raise and lower the adjusting ring (on the bottom of the valve) to the desired position. For a fine spray, or reduced water volumes and a large pattern recommended for low vehicle speed, set the slot to ¼ inch. For heavier soaking with larger volumes of water, set the slot wider. Tighten the black adjusting knob when finished.

The opening at the base of the spray head will allow 90-degree maximum fan width. To adjust for a narrower spray, while the black adjusting knob is loose, rotate the base to narrow the width. Tighten the black adjusting knob when finished.



Narrow setting

Spray Head Vertical Tilt Adjustment

Spray heads also may be tilted up or down if needed. To adjust, loosen the elbow couplings and adjust the swivel elbows down to the angle desired. Tighten bolts with a torque wrench to 38 foot-pounds.



Spray Operations

Depending upon the assembly date of your Spray King, there are several types of spray controllers.



Before engaging spray valves, make sure:

- To check surroundings and ensure any bystanders are kept away from the area of operation
- To be sure the valves are adjusted and tightened in place for the desired spray pattern
- To select the desired spray valves

IN-CAB TOUCH SCREEN CROSSFIRE SYSTEM



1. Left Spray Head Controls outboard (O/B) and inboard (I/B)
2. Water Level indicator
3. Open and Close All Valve Controls
4. Right Spray Head Controls outboard (O/B) and inboard (I/B)
5. Fire Hose Control
6. Water Pump On/Off switch (labeled Hose Reel)
7. Manual Left and Right Valve Spray Head controls
8. Camera Option (Do not use unless equipped)

Note: Activation of options can be done by pressing buttons on side of each option or by touching the screen. If you accidentally touch the camera shutter symbol, a black screen may appear if you don't have optional cameras. Touch the camera shutter symbol again and the black screen will disappear.



Engaging Spray Heads

After starting the vehicle there are two ways to engage the rear spray heads.

1. Press LEFT O/B to activate the left outboard sprayer, and LEFT I/B to activate the left inboard sprayer.
2. Press RIGHT O/B to activate the right outboard sprayer, and RIGHT I/B to activate the right inboard sprayer.

Press the individual buttons again to stop the heads individually. When the sprayers are active, they will light up yellow on the screen. Pressing LEFT O/B and LEFT I/B and/or RIGHT O/B and RIGHT I/B activates the pump, which turns the Hose Reel indicator and the on/off symbol green.

3. Alternatively: Use the Hose Reel button to activate the pump, then touch the OPEN ALL VALVES green bar at the top of the screen. You may also activate individual spray heads this way by pressing LEFT O/B and LEFT I/B and/or RIGHT O/B and RIGHT I/B. This opens all rear spray heads.
4. To close all valves, touch the CLOSE ALL VALVES green bar.

Note: At a 4% water level, the low water warning notice will appear and after one minute hydraulics will shut off.

Disengaging Spray Heads

To disengage the spray heads, press the LEFT O/B and LEFT I/B and/or RIGHT O/B and RIGHT I/B buttons again, or press CLOSE ALL VALVES. Turn off the pump by pressing HOSE REEL.

In-Cab Touch Screen Bosch System

Use touch screen in cab to control spray heads and monitor.

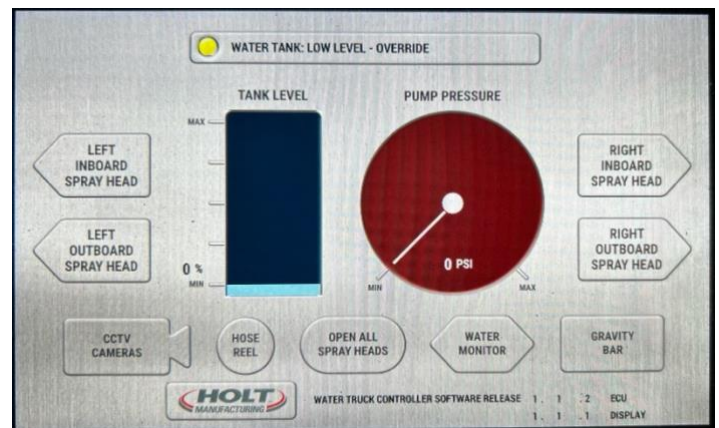
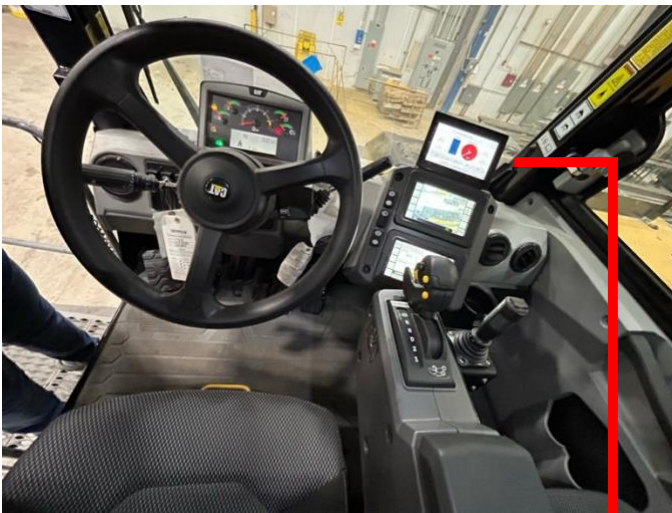

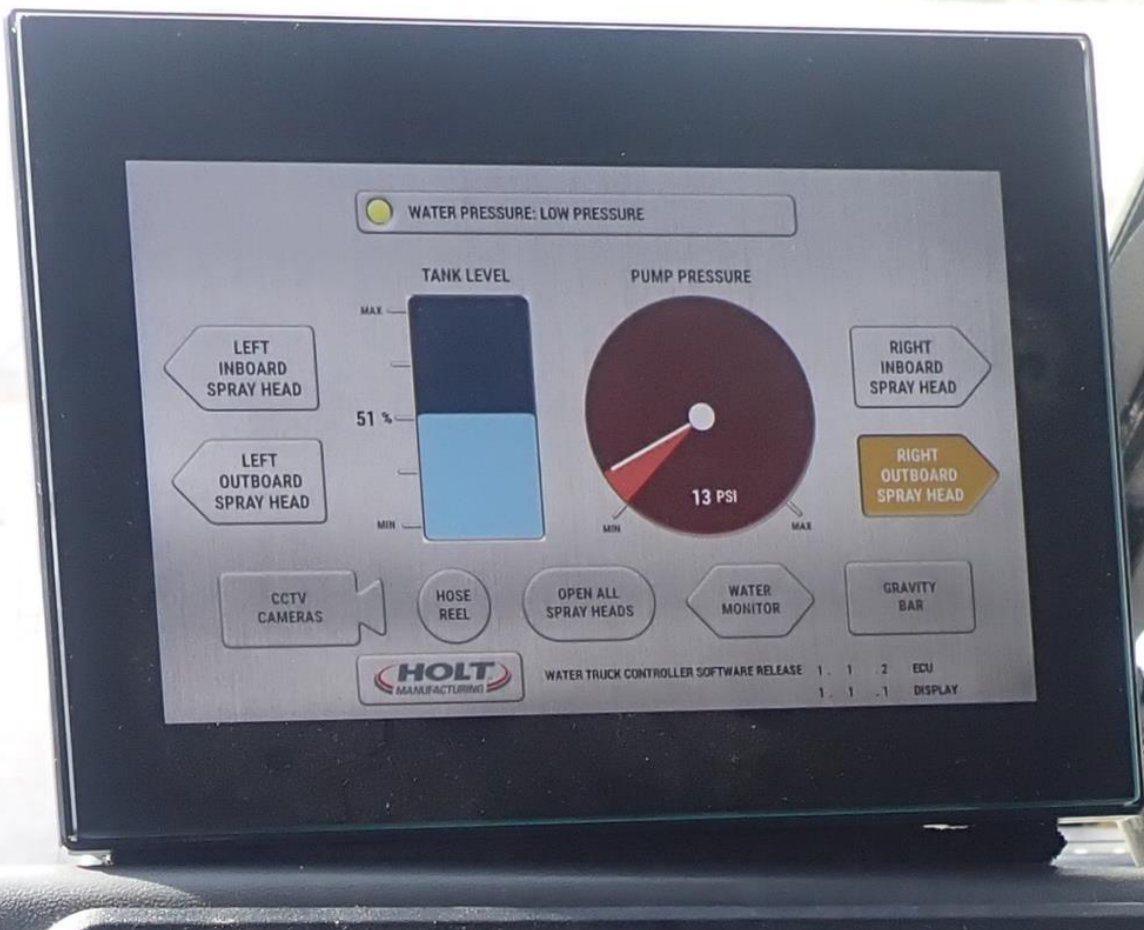

Engaging/Disengaging Spray Heads

At the top of screen is system monitoring. Fault codes and warnings will appear here with a red warning of a circuit failure, and amber warning for low water levels. There is also a display gauge for water pressure in manifold. To activate spray devices simply touch the portion of screen labeled for that device. It will change the display from white to gold. This indicates the function being commanded. Touching it again will stop the command.

Note: At a 4% water level, the low water warning notice will appear and after one minute hydraulics will shut off.

In-Cab Push Button Control System



Disengaging Spray Heads

To disengage the spray heads, press the L1/L2 and R1/R2 buttons again, or press CLOSE ALL VALVES. Turn off the pump by pressing HOSE REEL.

Driving While Spraying

Select a controlled gear, in most trucks L1, L2, or L3, to apply water. For optimal spray distance, run the vehicle slowly at a controlled speed applying full RPMs. Conduct a test run to determine optimal speed and RPMs for the application.

Disengage the spray heads at any time while driving. Reengage the heads at low RPMs or idle.

At a 4% water level, there will be low water warning come on for all touch screen systems. This will start a timer that will shut off water pump in 60 seconds.

Note: There is no warning for the push button box.

Hose Reel

HOLT Spray King is equipped with COXREELS® outlet hose reels.

Before operating, check for correct operation by pulling out some of the hose. A slight friction of drag should be noticed. This is to prevent backlash when pulling out the hose.

Adjust drag brake by turning clockwise to add tension and counterclockwise to decrease tension. The adjustment for the hose reel brake is located on the right side of reel on center pivot shaft.

Retract hose manually (or use electric retract by pressing and holding button) when finished with use and secure spray nozzle end in holder.

Using the Hose Reel

Turn on hose reel in cab by pressing Hose Reel on touch screens systems and water pump on push button box. Open ball valve on rear of truck at hose reel.

Remove nozzle from holder.

Pull hose to extend to desired length. Use water flow valve on nozzle to spray water.

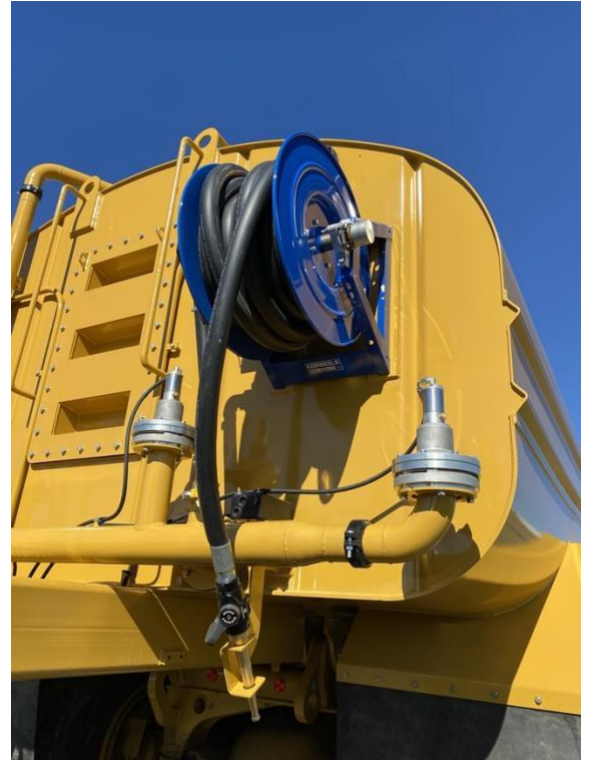

Stowing Hose

Shut off control at nozzle head.

Close ball valve on rear of truck at hose reel.

To drain hose, open control at nozzle before retracting hose.

Retract and rewind hose manually, or if equipped, use electric retract by pressing black button.

Using the Gravity Bar

The gravity bar lays a heavy but narrow pattern of water directly onto the ground surface, used for confined areas or during high wind when spraying isn't the most efficient delivery method. Water is not under pressure but drains from the tank with gravity only.



When using the gravity bar, it is not necessary to operate at higher RPM as the water is released only with gravity and not under pressure.

Activate the pump by touching the HOSE REEL circle, bottom center. Then touch on GRAVITY BAR. To disengage, touch the HOSE REEL circle again.

Monitor Operation



The HOLT Spray King is equipped with a Nitro HD® monitor and joystick controller. The joystick provides basic directional movement of the monitor and actuation of the nozzle.

The controller for the Nitro HD is mounted on the front of the tank.



Before operating, inspect the Nitro system for signs of excessive wear or abnormal damage, water or hydraulic hose leaks.

Look for signs of loose mounting or wiring connections.

Flow water to check the nozzle pattern; if pattern is disrupted, clear any debris. Check any joints for leaks.

Store nozzle facing downward to drain and to lower the profile and height of the truck. Monitor could be damaged by low hanging tree limbs or other obstructions.

Rotation Limits

For safety, the fire hose is set to of 180 degrees horizontal rotation and 90 degrees vertical rotation.



Warning: High pressure water - Do not operate monitor until all personnel are a safe distance away from the vehicle. Equipment damage can be caused by water flowing at maximum pressure. Don't point monitor directly at equipment or any sensitive components.

Engaging the Water Monitor



Touch the HOSE REEL circle, then touch the FIRE HOSE bar. The FIRE HOSE bar will illuminate, and the spray symbol on the truck diagram will indicate engagement.

Use the joystick to control the direction of the water spray.

- UP movement: pull back on the joystick handle
- DOWN movement: push forward on the joystick handle
- RIGHT movement: pull the joystick handle to the right
- LEFT movement: pull the joystick handle to the left
- TO STREAM nozzle movement: press and hold the right rocker switch (top of joystick)
- TO FOG nozzle movement: press and hold the left rocker switch (top of joystick)
- The trigger on the joystick handle is an option and has no function for Spray King.

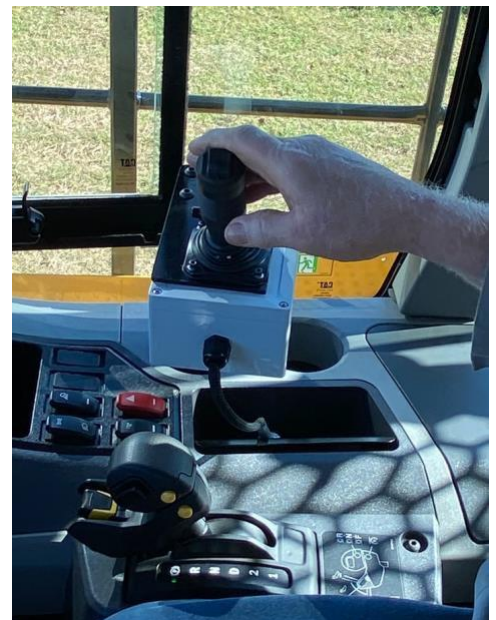

Operating the ROJO Sprayers (Optional)

ROJOs are rotary joints, optional spray heads that can be installed on the front of the tank.



Other Parts: Pump



Warning: Rotating parts. Can catch hands, feet, or clothing. Stay clear of equipment and keep shields in place while pump is running. Stop motor or engine before servicing pump.

HOLT Spray King includes a Berkeley®-style water pump.

- Periodically inspect pump and system components for signs of wear, damaged or leaking hoses, excessive vibration, or unusual sounds.
- Check operating temperature: normal is 150 degrees F. If the surface temperature of the pump bracket or driver is excessive, discontinue use and call for service.
- To prevent freezing, draining the tank will drain the pump, see below. An additional drain valve is at the base of the pump. Do not allow pump, piping, or any other system component containing water to freeze. Freezing may damage system, leading to injury or flooding. Allowing pump or system components to freeze will void warranty.
- Pump water only.
- Never run pump dry.

Draining the Pump



At left, open 2" ball valve to drain the tank and the pump.

Below, the riser pipe will automatically drain when the butterfly valve shuts off water to the monitor.





WARNING: Drain pump and lines when experiencing freezing weather.

Remove the plug on the bottom of the pump to drain any residual water.



IFM Hydraulic Controller (Installed 2022 -)

With the key on, the IFM hydraulic controller box, located under the center rear of the tank, will cycle through test mode before showing a green light in ready mode.

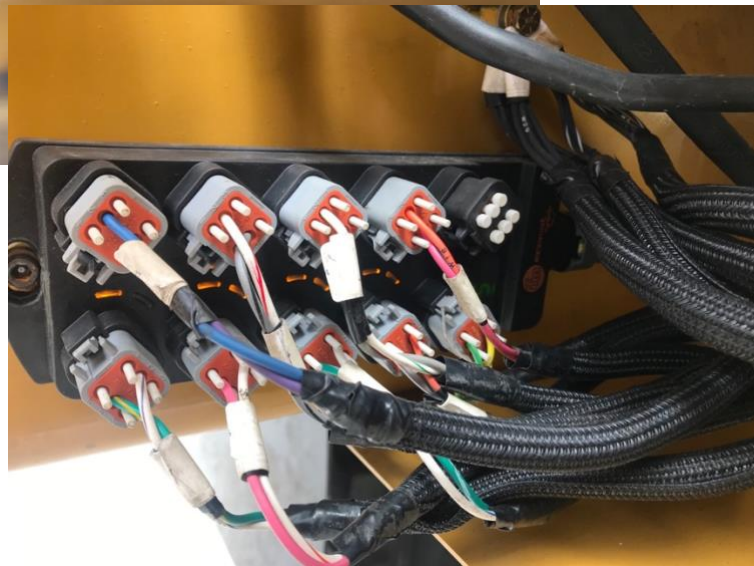

Crossfire Hydraulic Controller (installed pre-2022)

With the key on, the Crossfire hydraulic controller box, located under the center rear of the tank, will cycle through test mode before showing a constant green light in ready mode.



Butterfly Valve



WARNING: Crush/Pinch Risk. Do not place your hand or tools near the butterfly valve (if equipped) when the truck is in operation.

The butterfly valve controls water flow to the monitor. Examine for wear and leaks.



MAINTENANCE

Pump Maintenance, Start Up and Winterization

For less down time and to extend the life of the pump, keep the pump well maintained.

A routine maintenance and inspection schedule should be set up on a weekly, quarterly, and annual basis with records kept of these actions.

Weekly Checks: Lubrication

LIQUID END of pump requires no lubrication. Wear rings, packing rings, and models using a mechanical shaft seal, are lubricated by the liquid being pumped. Do not run dry! BEARING FRAME - add approximately 2 ounces of a lithium-based NGLI No. 2 extra pressure ball bearing grease to each bearing during quarterly inspection. Excess grease will cause bearings to run hot.

The following are factory approved brands of grease for use with Berkeley Pumps: Alvania EP2, Shell Oil; Mobilith AW2, Mobil Oil, Ronex MP, Exxon, Litholine EP2, Atlantic Richfield; and Amolith EP2, Amoco.

NOTE: Grease fitting in packing area is for priming only. See PRIMING in start-up section for instruction.

Weekly Observational Maintenance

Observe the following:

- **VIBRATION:** All rotating machines can be expected to produce some vibration, however, excessive vibration can reduce the life of the unit. If the vibration seems excessive, discontinue operation, determine cause of the excessive vibration, and correct.
- **NOISE:** When the unit is operating under load, listen closely for unusual sounds that might indicate that the unit is in distress. Determine the cause and correct.
- **OPERATING TEMPERATURE:** During operation, heat is dissipated from the pump and the driver. After a short period of time, the surface of the pump bracket will be quite warm (as high as 150°F), which is normal. If the surface temperature of the pump bracket or driver is excessive, discontinue operation, determine cause of the excessive temperature rise, and correct. Bearings will run hotter for a brief run-in period after packing which is normal. However, worn bearings will cause excessive temperatures and need to be replaced. The pump unit is cooled by the water. For quarterly and annual maintenance, refer to check list on the following page.



WARNING: To avoid damage, drain pump during freezing weather.

Winterizing

If pump is to be out of service for an extended period, such as the winter months, the following storage procedures should be followed.

- Remove exterior dirt and grime or any substance that may trap moisture. Exposed metal is subject to oxidation, prime and repaint if necessary. If this is not possible, coat with grease or heavy oil.
- Flush suction and discharge lines. Check for leaks and replace any worn gaskets.
- Remove lowest plug-in pump and drain pump casing and suction and discharge lines.
- Lubricate bearings.
- If possible, keep unit clean and dry during storage period to guard against corrosion.
- Seal all open ports to keep out foreign objects such as insects, rodents, dust and dirt.
- Rotate driver shaft periodically to prevent freeze-up of internal components.
- Shelter unit from elements if possible.
- Work oil into impeller wear ring by dripping oil into the gap while rotating by hand.

Spring Start-Up

- Inject sufficient grease into the bearings to displace old grease.
- Visual inspection.
- Rotate by hand, if any binding occurs, disassemble, and inspect.

Quarterly and annual inspections are on the next page.

Maintenance
Routine Inspection
Record

I. QUARTERLY INSPECTION

- Inspect all system piping connections for leakage or possible misalignment.
- Check pump foundation for soundness and see that all hold-down bolts are secure.
- Complete any lubrication requirements as dictated by pump and driver owner's manual.
- Inspect packing or mechanical seal for possible replacement. Examine shaft sleeve, if present, for wear and replace if necessary.
- Inspect pumping plant panel for signs of wear (ie: replace pitted contactors, etc., as needed).
- Check pump and motor bearings from signs of wear. Repack or replace as necessary.
- Check alignment of couplings and/or pulleys and belt tension if applicable.
- _____

II. QUARTERLY INSPECTION

- Inspect all system piping connections for leakage or possible misalignment.
- Check pump foundation for soundness and see that all hold-down bolts are secure.
- Complete any lubrication requirements as dictated by pump and driver owner's manual.
- Inspect packing or mechanical seal for possible replacement. Examine shaft sleeve, if present, for wear and replace if necessary.
- Inspect pumping plant panel for signs of wear (ie: replace pitted contactors, etc., as needed).
- Check pump and motor bearings from signs of wear. Repack or replace as necessary.
- Check alignment of couplings and/or pulleys and belt tension if applicable.
- _____

NOTES:

III. QUARTERLY INSPECTION

- Inspect all system piping connections for leakage or possible misalignment.
- Check pump foundation for soundness and see that all hold-down bolts are secure.
- Complete any lubrication requirements as dictated by pump and driver owner's manual.
- Inspect packing or mechanical seal for possible replacement. Examine shaft sleeve, if present, for wear and replace if necessary.
- Inspect pumping plant panel for signs of wear (ie: replace pitted contactors, etc., as needed).
- Check pump and motor bearings from signs of wear. Repack or replace as necessary.
- Check alignment of couplings and/or pulleys and belt tension if applicable.
- _____

IV. QUARTERLY INSPECTION

- Inspect all system piping connections for leakage or possible misalignment.
- Check pump foundation for soundness and see that all hold-down bolts are secure.
- Complete any lubrication requirements as dictated by pump and driver owner's manual.
- Inspect packing or mechanical seal for possible replacement. Examine shaft sleeve, if present, for wear and replace if necessary.
- Inspect pumping plant panel for signs of wear (ie: replace pitted contactors, etc., as needed).
- Check pump and motor bearings from signs of wear. Repack or replace as necessary.
- Check alignment of couplings and/or pulleys and belt tension if applicable.
- _____

ANNUAL INSPECTION

- Inspect pump and entire pumping system for signs of wear.
- Inspect system valves, screens, etc.
- If electric motor is used, check windings for degradation, rewind if necessary.
- Check pump impeller eye for clearance.
- Inspect impeller, volute case, and seal chamber for signs of excessive wear or corrosion.

Maintenance: Water Monitor

The complete system should be inspected before each use or once a month on a scheduled basis. Visually inspect the nozzle carefully for damage:

- Check the system for signs of excessive wear or abnormal damage
- Examine monitor, nozzle, joystick, and wire harnesses for loose mounting or wiring connections.

Flow water as a test to check the nozzle pattern. If the pattern is disrupted, clear the nozzle of debris. If the obstruction remains, remove the nozzle and check for debris lodged between the nozzle stem and monitor or in the nozzle stream shapers.



Warning: Do not use high pressure spray to clean the Nitro HD. This can damage seals and lead to serious damage of electrical components.

During nozzle flow test, inspect the monitor swivel joints for leaks, and inspect all exposed wiring for signs of damage.

Grease fittings are provided for the up-down and left-right gear cases. Routine greasing should be done. Mobil™ Mobilux™ EP 2 grease is recommended to lubricate the monitor gearing.

ABOUT HOLT MANUFACTURING

The Holt name has been associated with a heritage of innovation for more than 100 years. HOLT Manufacturing owners Peter J. Holt and Corinna Holt Richter are direct descendants of Benjamin Holt, who revolutionized farming in the late 1800s with the Holt Combined Harvester and then in 1904 developed the first successful track-type tractor, which he named the "Caterpillar."

Within HOLT Manufacturing and the family of Holt companies, innovation has meant everything from the original Caterpillar track-type tractor to today's Spray King® Water Tanks, engine and generator packaging, root plows, custom attachments, and special application machines. HOLT Manufacturing's values date all the way back to the incredible work ethic of Benjamin Holt. Centered around a belief in unmatched customer service, Holt instilled many of the values that still live within HOLT Manufacturing to this day. Holt developed "link belt" combined harvesters in the late 1880's. By the turn of the century, Holt Manufacturing was the largest combine manufacturer in America and was exporting to countries around the world.

Finding that heavy farm equipment bogged down in the loose soil of the San Joaquin River Delta in California, Holt put his inventive mind to work again. In 1904, Holt Manufacturing introduced the first successful track-type tractor, which they named the "Caterpillar." Its continued success was assured once Holt found a way to power it with a gasoline engine in 1908. In 1925, Holt Manufacturing Company merged with one of its longtime competitors to form Caterpillar Tractor Company. Today, Caterpillar, Inc., is the world's largest manufacturer of construction equipment.

In 1933, Ben's second son William K. "Bill" Holt established the William K. Holt Machinery Co. in San Antonio, Texas, as a Caterpillar equipment dealership. Seeing the need for specialized land-clearing equipment, Bill Holt encouraged the development of the Holt root plow during the 1940's. In quick succession he developed other brush management implements and today HOLT land-clearing equipment is sold all over the world, a tribute to the second generation of Holt ingenuity.

Over the years, this custom design and manufacturing has included specialized tools, modifications to existing products, and development of unique products for unique customer applications. Today, the original William K. Holt Machinery company is known as HOLT CAT, the largest Caterpillar equipment dealership in the United States. HOLT CAT sells, rents and services Caterpillar machines, engines and generator sets in a 118-county territory in Texas. Five other companies, including HOLT Manufacturing, make up the Holt Companies, a name synonymous with quality, integrity, and commitment to customer service.

The HOLT Manufacturing company name lives on through Benjamin Holt's direct descendants and a team who believe in his original values and vision. The innovation that started with linked belts and self-laying tracks also continues through modern technology and advances.